

SPECIFICATION

FOR APPROVAL

Part number : BST-0843A
Description : SMD Magnetic transducer
(RoHS compliance / non washable)
Country of origin : Republic of Korea
Date : 27th Sep 2013
Drawn by : Donggyu Kim

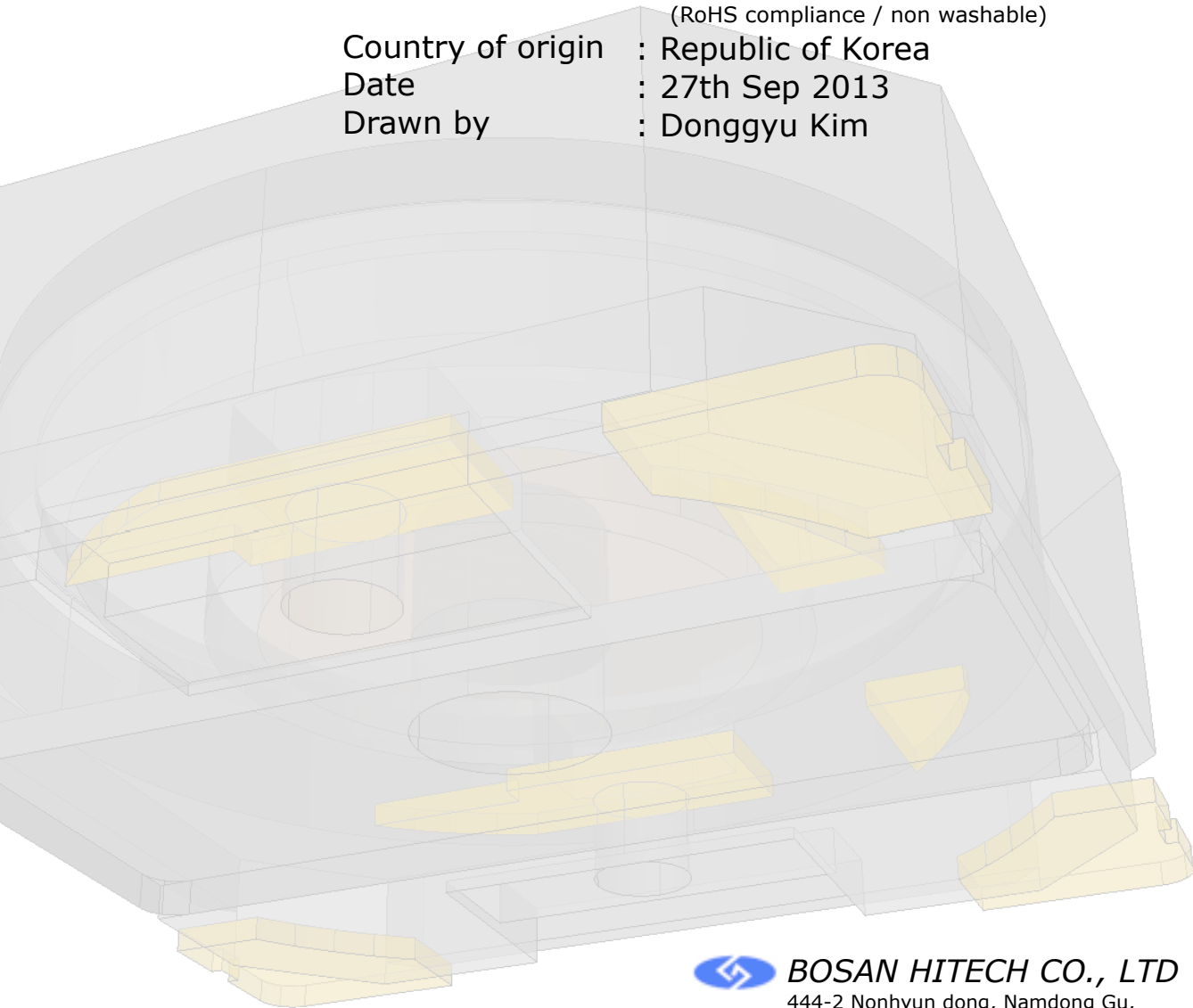

BOSAN HITECH CO., LTD

444-2 Nonhyun dong, Namdong Gu,
Incheon city, 405-849, Republic of Korea.

Phone : +82-32-818-2125, Fax : +82-32-818-8780

email : andy@bosanhitech.com

INDEX

Revision Note	3
1. Scope	4
2. Product Photos	
3. Electrical acoustical characteristics	
4. Mechanical Characteristics	5
1) Dimensions	
2) Date code recognition method	
5. Reliability test	6
6. Warranty	
7. Operating instructions	7
1) recommended input signal	
2) recommended circuit diagram	
8. Soldering instructions	8
1) recommended SMT reflow temperature profile	
2) recommended PCB pattern	
3) recommended iron soldering condition	9
4) washing conditions	
9. Trouble shootings	
10. Sound measuring instructions	10
1) measuring conditions	
2) Frequency - Sound pressure level curve	
11. Packing details	11
1) reel and carrier	
2) carton	12

REVISION NOTE

#	DATE	CONTENT	BY
1	22 Nov 2011	Initial release	Donggyu Kim
2	22 Mar 2013	Tolerance, Typ Sound Level, Reflow Temp Profile	Donggyu Kim
3	27 Sep 2013	Operating Temperature, Storage Temperature	Jay Hwang
4	15 Nov 2013	Max Current Consumption	Jay Hwang
5			
6			
7			
8			
9			
10			
11			
12			

1. Scope

This document specifies a SMD magnetic transducer/buzzer, and the main application of this part is for an electronic device which requires audible feedback for human ears recognition.

2. Product Photos

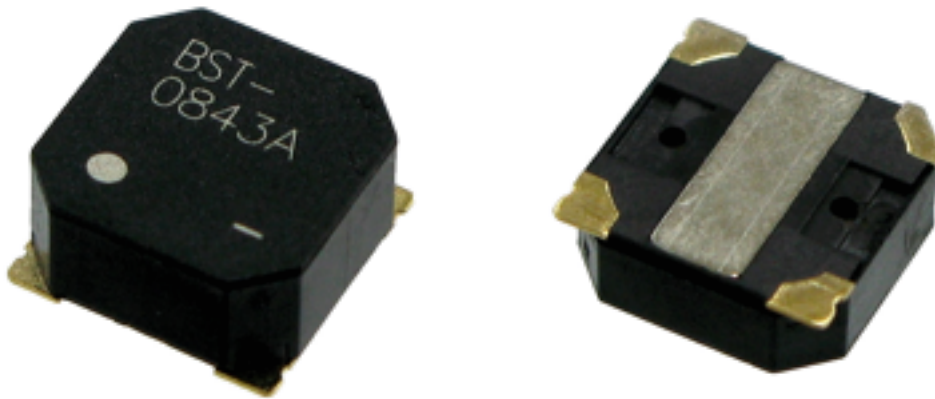

* Above photo is an advertising purpose, so its appearance/printing may be different from an actual product

3. Electrical and acoustical characteristics

PARAMETERS	SPECIFICATIONS	UNIT
Rated voltage	3.6	Vo-p
Operating voltage	2.5 ~ 4.5	Vo-p
Current consumption	max 80	mA
Coil DC resistance	16 ± 3	Ω
Operating frequency *	10 ~ 10,000	Hz
Rated frequency	2,700	Hz
Sound pressure level **	Min. 88 , Typ. 90	dBA
Operating temperature	-40 ~ +90	°C
Storage temperature	-40 ~ +90	°C

* This part is designed to make its max sound at 2,700 Hz and sound will decrease in other frequency range

** measured from 10 cm distance with input signal described in above table.

4. Mechanical characteristics

1) Dimensions

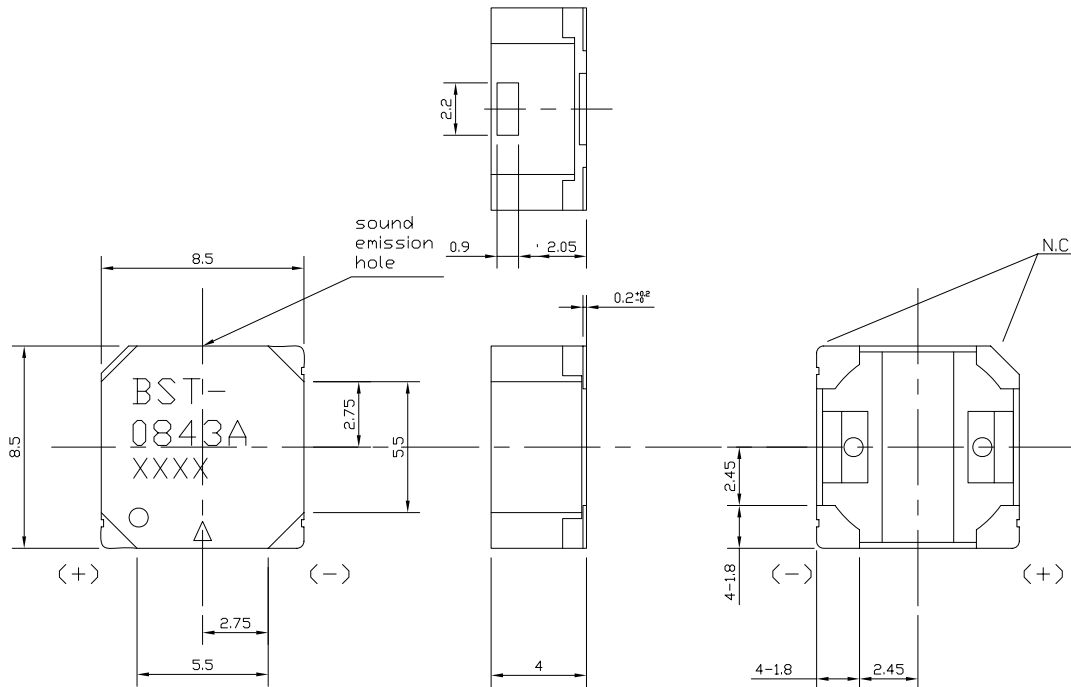

Housing Material : Nylon #46
Lead material : Gold plated Brass
Weight : 0.45 grams
general tolerance : 0.3 mm

2) Date code recognition method

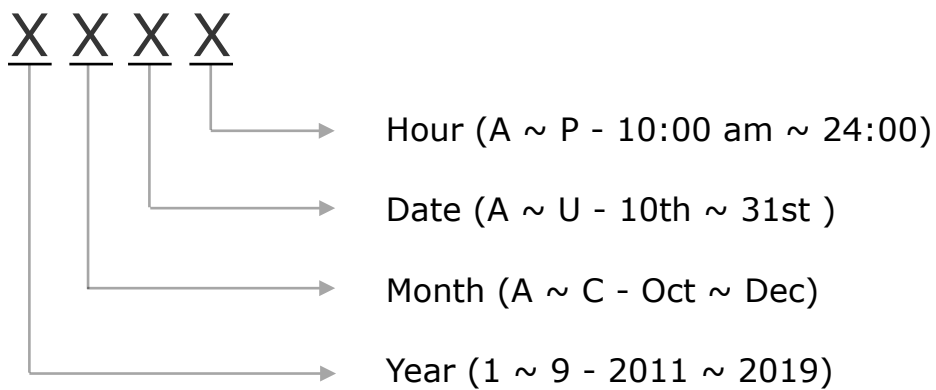

5. Reliability Test

No.	Item	description
1	low storage temperature	Store in -40°C for 96 hours, then expose to room temperature for 4 hours
2	high storage temperature	Store in +90°C for 96 hours, then expose to room temperature for 4 hours
3	temperature cycle	Total 50 cycles of low & high temperature. Each cycle consists of 30 mins of -40°C and 30 mins of +90°C
4	humidity resistance	Storing 72 hours at 40°C with 95% relative humidity, then expose to room temperature for 4 hours
5	random vibration	Vibrating part with 55 Hz for 10 mins and 150 Hz for 10 mins, each 20 mins for X,Y,X axis(total 60 mins). random gravity range : 0.5 ~ 10.0G,
6	drop test	Free fall onto concrete floor from 50cm height, 10 times.
7	shear test	Pulling a part mounted on PCB with strength of 1kg force for 30 seconds.
8	Operating life	Operating a part at its rated input signal for 1000 hours at room temperature

6. Warranty

- 1) period of warranty : 6 months from ship date
- 2) Product life : 5 years from its production date under manufacturer’s storage.
- 3) This part is manufactured, inspected and packed in Republic of Korea
- 4) Any failed parts worked under conditions not specified in this document are not responsible for the manufacturer.
- 5) Any parts measured by methods not specified in this document are not warranted.
- 6) Unassembled or thermally damaged parts won’t be retrieved for analysis / corrective action report purpose. Customer is responsible for returning parts as original as possible for any inspection / analysis purpose.
- 7) Manufacturer’s guaranteed quality breakpoint is 300 ppm after SMT. Customers who are experiencing failure rate that is higher than 300 ppm can ask manufacturer for refund or free replacement.
- 8) This component complies below environmental regulations

2002/95/EC - Restriction of Hazardous Substances Directive
 EC/2037/2000 - Regulation on Ozone Depleting Substances
 SVHC under REACH regulation
 Halogen free under IPC regulation

7. Operating instructions

1) recommended input signal

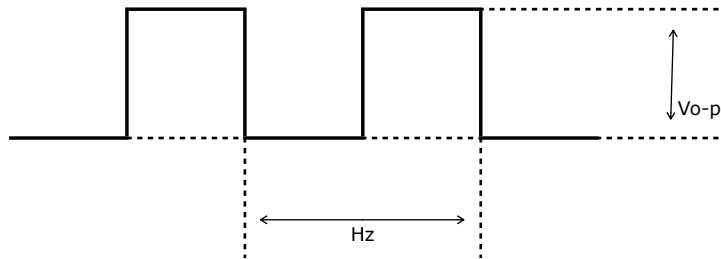

This product is designed to make its max sound when AC input signal shown in above figure with its rated voltage and frequency flows.

PWM is the most frequently used input signal source in general.

Sine wave can also be used as an input signal.

2) recommended circuit diagram

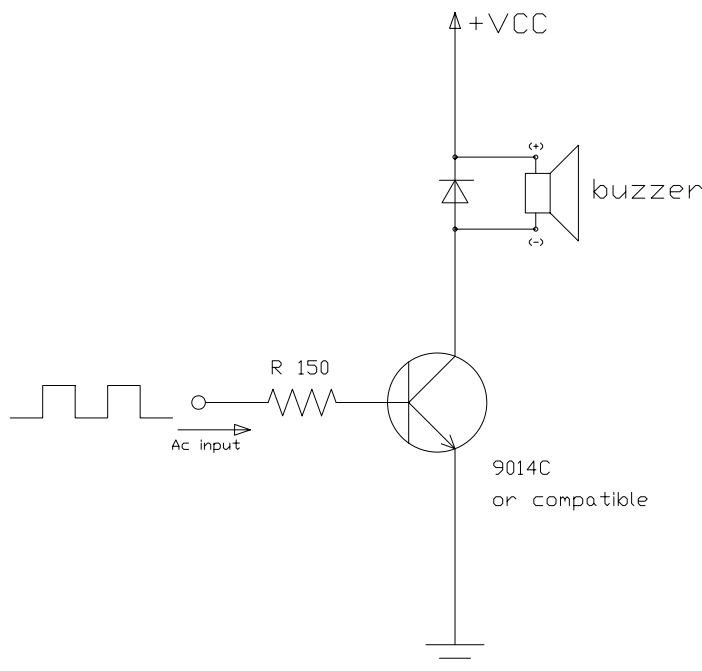

To minimize current consumption, please consider adjust its duty ratio from 50:50 to 10:90(high : low) then the consumption will decrease by about 30~40%.

Basic program source which demonstrates melody and click sound is available in C or hex format. Please [contact us](#) for technical support.

Reversed polarity will result in low sound.

8. Soldering instructions

1) Recommended SMT reflow temperature profile

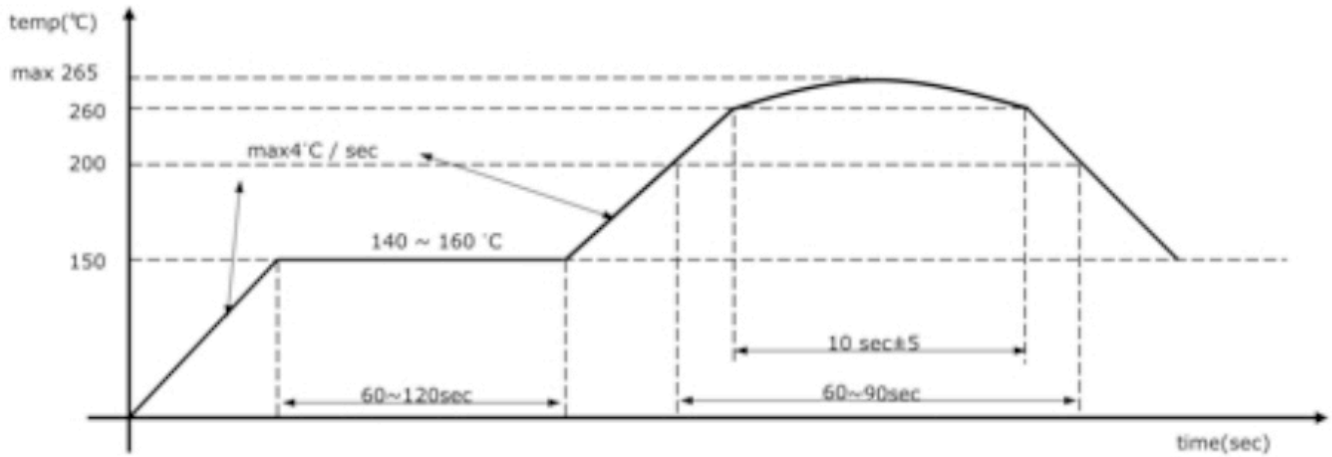

This part is able to withstand above temperature condition by 2 passes

2) Recommended PCB pattern

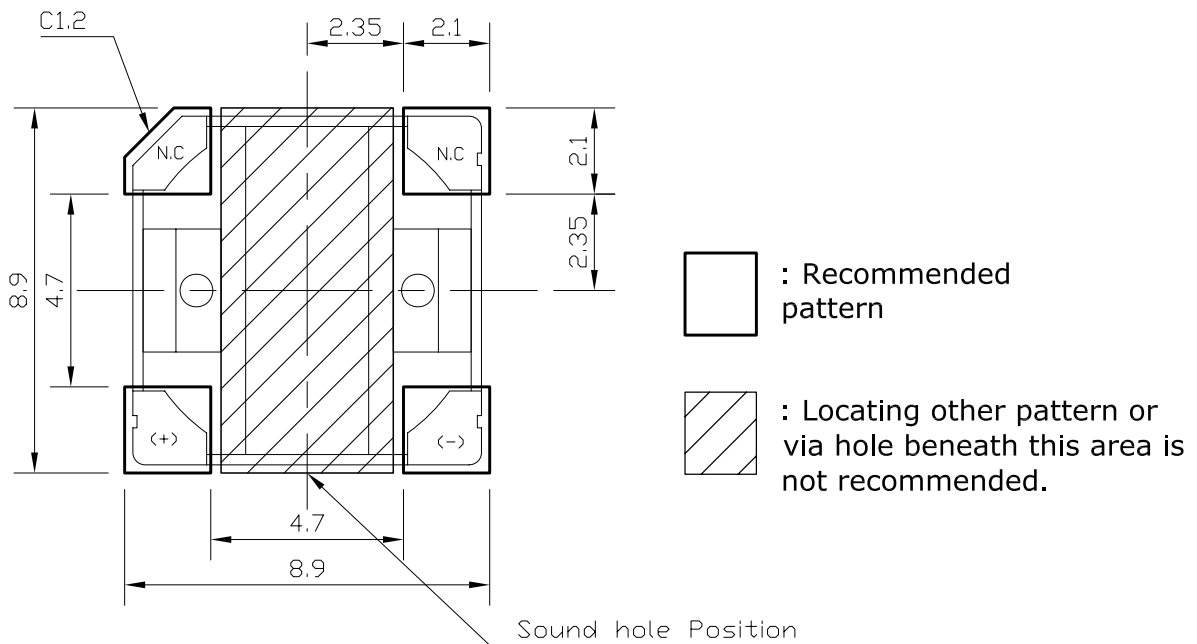

3) Recommended iron soldering condition

This part is designed for SMT soldering only. Working with manual iron is not recommended except sample test or rework.

In case of iron soldering, the iron tip temperature should be lower than 240 degree celsius and soldering time should be shorter than 15 seconds.

4) Washing conditions

This part is not washable type. So soaking into solvent or water will result in decrease of sound level.

9. Trouble shootings

description	Possible reason	Possible solution
No sound	Input signal is DC	Please use square / sinusoidal AC signal.
	Wrong pin connection	Please see page 5 and check the pin connections
Low sound level	Polarity reverse	Change input signal polarity
	Solvent penetrated	Washing should be minimized.
	Internal coil melt down	Please use an iron tip with temperature lower than 265 °C or check the input voltage
	Demagnetized	This product has permanent magnet inside. In case of contact with strong magnet force it will be de-magnetized and this possibly will decrease sound level.
Noisy sound	Voltage is too high	Powerful current will make this part's diaphragm vibrates stronger than its designed allowance
	Frequency is low	If signal's frequency is at the part's resonant frequency, it will result in noisy sound. Please raise frequency by about 50 Hz.

10. Sound measuring instructions

1) Measuring conditions

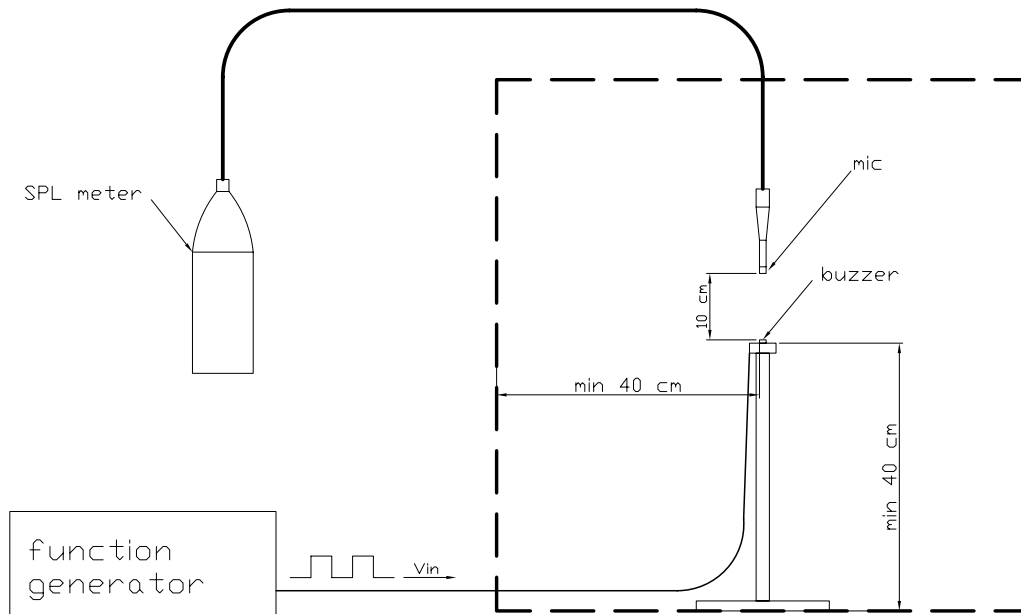

* Sound hole direction should be toward mic.

2) Frequency - Sound pressure level(SPL) curve

X:2.7200kHz *Y:92.02dB* ZA:Live Curve SSR T. RMS

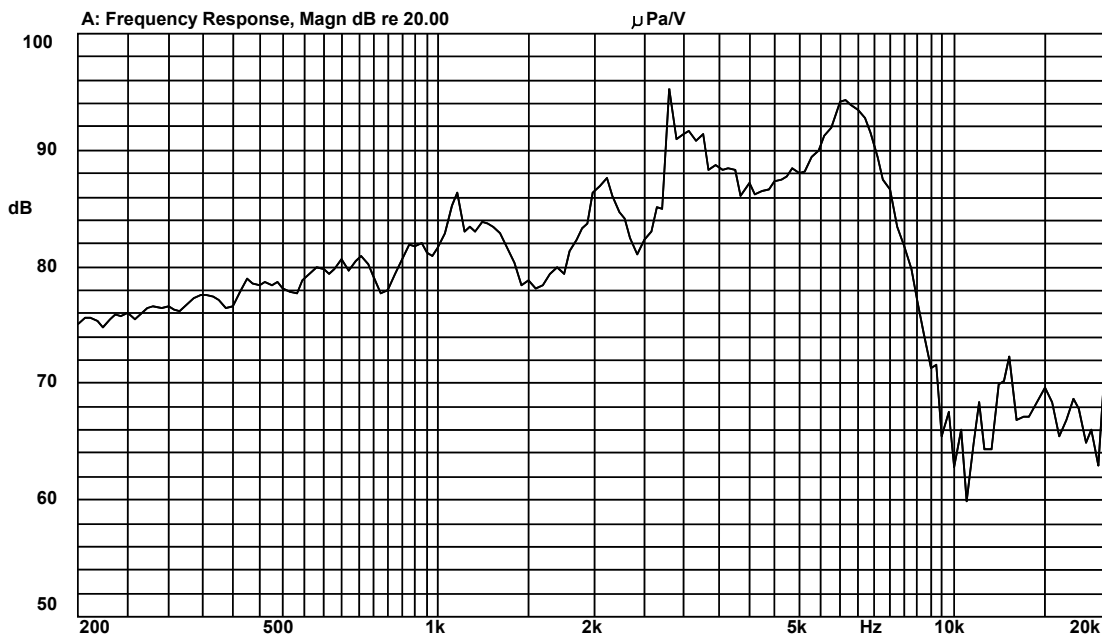

Mode: SSR



11. Packing details

1) Reel and Carrier

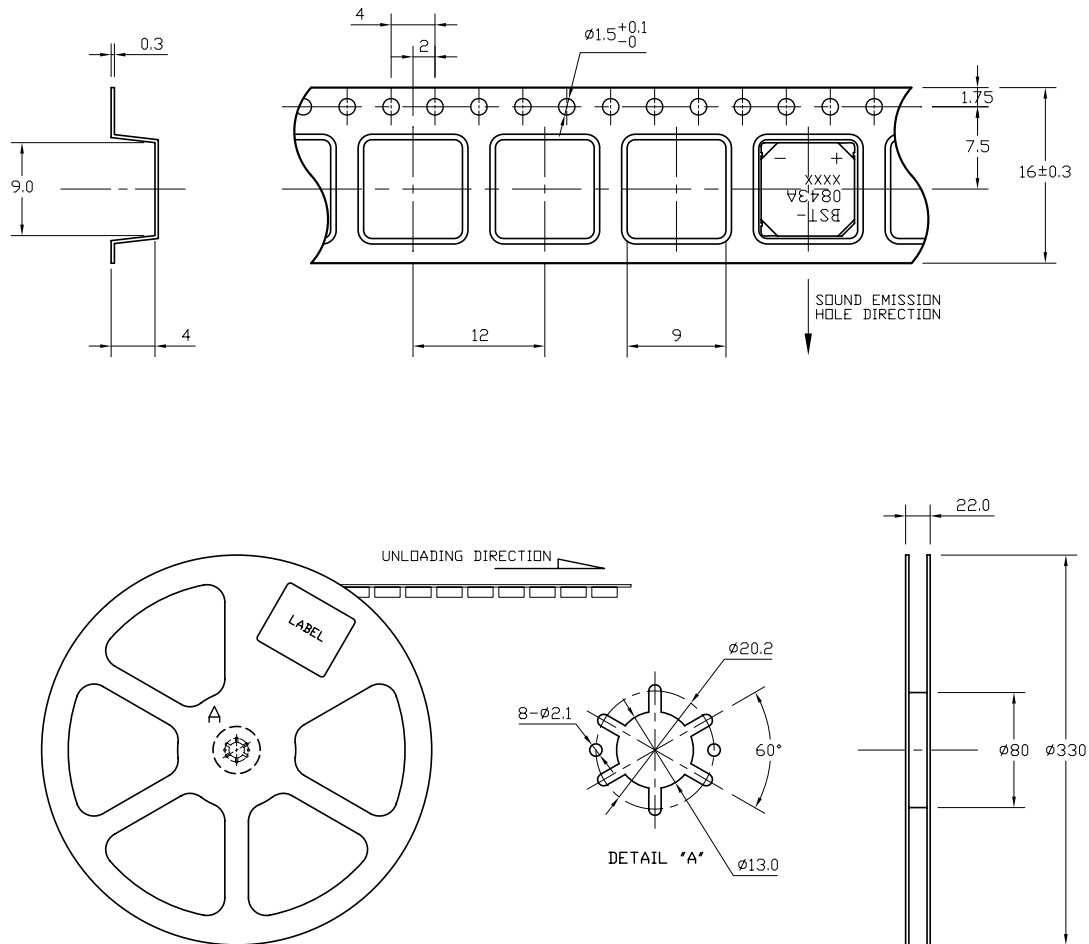

<<Remarks>>

- Unit : mm
- General corner unless specified : R 0.25 mm
- General tolerance : 0.1 mm
- Reel and carrier specification refers to JIS C0806
- Quantity per a reel is 1,000 EA
- 50 pockets at both end are empty for leader purpose.

2) Carton

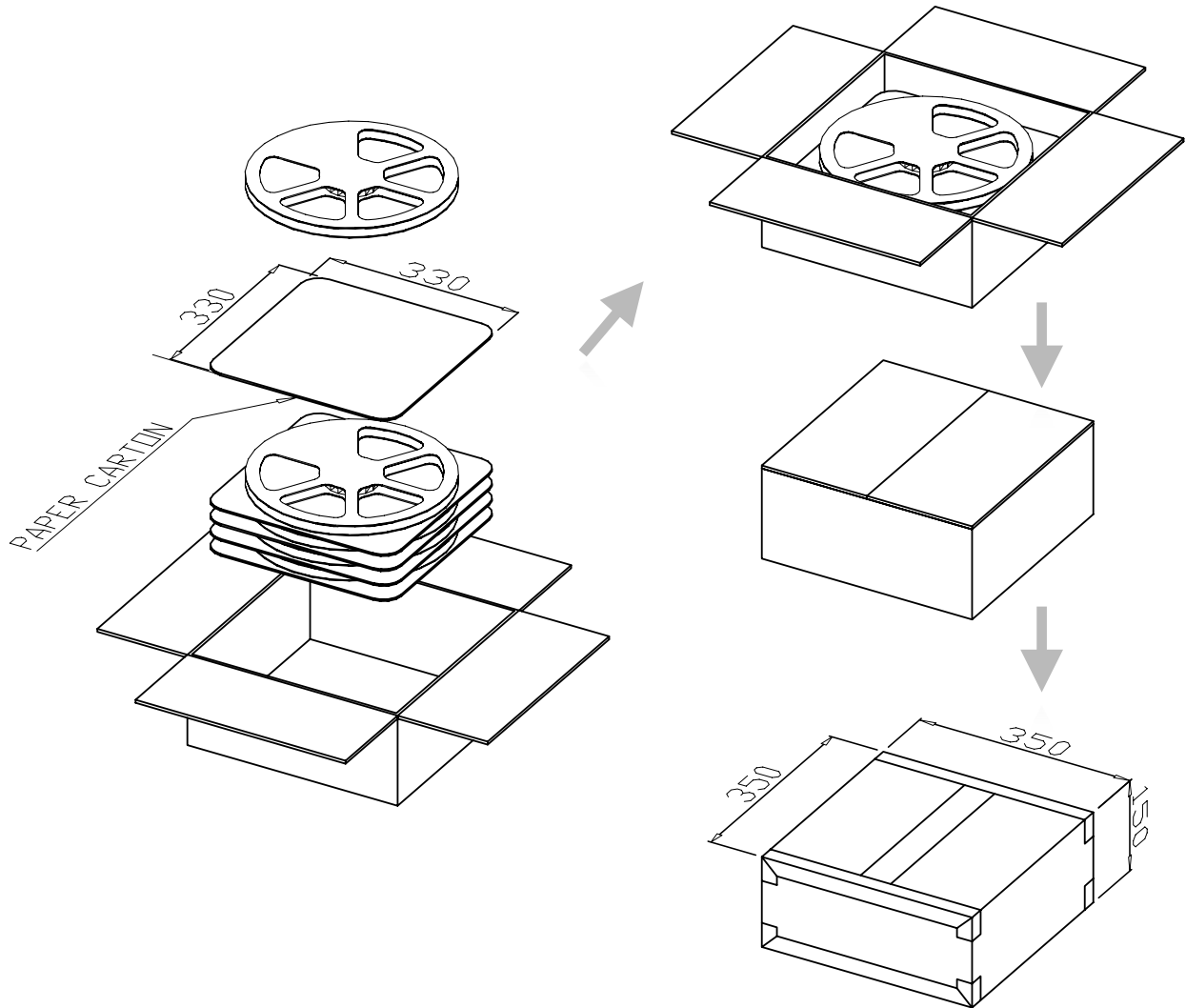

<<Remarks>>

- . Unit : mm
- . Reels per a carton : 5 EA
- . Net weight of one carton : 2.2 kg
- . Gross weight of one carton : 4.7 kg
- . Water resistant packaging for vessel shipment is available.
- . Labels will be attached onto each reels and cartons.
- . Shipment with smaller quantity than 5,000 EA can be different from given details.